

Dear customer,

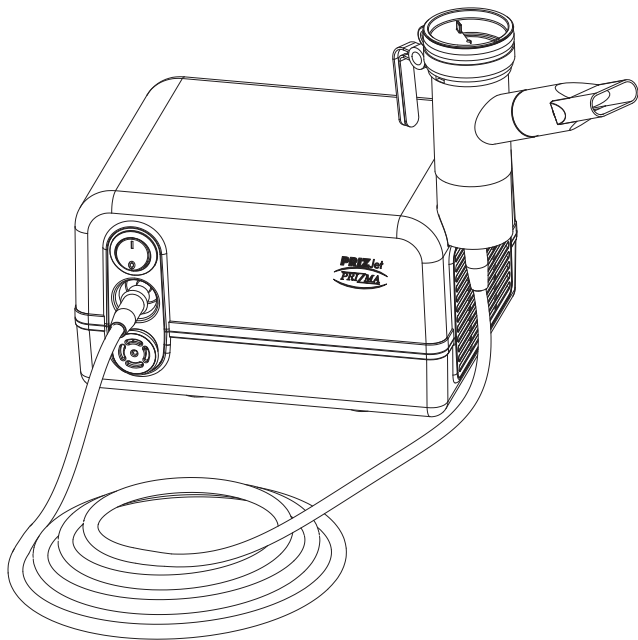

PRIZJet is a medical device intended for the successful treatment of asthma, bronchitis, allergies and other respiratory disorders. Use it only according to the recommendations issued by your doctor or therapist.

PRIZJet has two main parts, the compressor and nebuliser kit. Filtered compressed air from the compressor transforms medication inside the nebuliser kit to microscopic aerosol particles suitable for very easy inhalation.

We wish you good health and all the best in the future
PRIZMA, Kragujevac

Contents

History of document revisions	2
Intended use	3
Before using the device	4
Important safety information	4
1. Know your device	8
2. Guide to using the PRIZJet	10
Operating instructions	11
3. Preparing the nebuliser for use	11
4. Taking medication	16
4.1 Inhalation	16
Care and maintenance	20
5. Cleaning and daily disinfecting	20
5.1 Cleaning	20
5.2 Disinfecting the nebulising parts	22
6. Maintenance and storage	23
7. Changing the air filter	24
8. Troubleshooting	26
9. Technical data	28
10. Optional parts and accessories	31

History of document revisions



Version	Date	Description of changes
1.0	01. 03. 2012.	Initial version
1.1	01. 02. 2013.	Changes on section 4.2.
1.2	01. 01. 2017.	Changes on sections "Important safety information" and "Technical data"
1.3	01. 03. 2018.	Changes on illustrations

Intended use

Intended use	Device is intended to be used for inhalation of medication for respiratory disorders.
Intended users	<ul style="list-style-type: none"> • Medical professionals (doctor, nurse, therapist, ...) • Healthcare personnel or patients trained and guided by qualified medical professionals. User must be capable of understanding the instruction manual and general device operation.
Intended patients	Conscious, spontaneously breathing patients.
Working environment	Device is intended for use in a medical facility such as hospital, clinic, doctors office and in room of general household.
Lifetime	Lifetime of main parts of the device if based on 10 minutes inhalation with saline, 3 times a day, at room temperature (23 °C). Lifetime may vary depending on working environment. <ul style="list-style-type: none"> Compressor - 5 years Nebuliser kit - 1 year Mouthpiece - 1 year Air tube - 1 year Air filter - 60 days Child mask - 1 year Adult mask - 1 year
Precautions for use	User must read warnings and cautions described in this instruction manual.

Important safety information

Read all the information in this instruction manual and any of the supplied documents before using the device.

<i>Description of symbols used regarding safety of device</i>	
 Warning	Potentially dangerous situation which, if not avoided, may result in injuries or physical damage of device.
 Caution	Potentially dangerous situation which, if not avoided, may result in minor or moderate injuries, or physical damage.

(Usage)

- Keep device out of reach of babies and children. Device contains small parts that can be swallowed.
- In order to prevent strangulation by the power cord or air tube, or injuries caused by mishandling, please provide close supervision when this device is being used by, on or near children or invalids.
- For type, dosage and use of medication follow instructions of your doctor or therapist.
- For inhalation purposes do not use only water.
- Keep device and accessories in a clean place.
- Clean and disinfect nebuliser kit, mouthpiece and mask:
 - before first use and after purchase of device,
 - if the device is not used for a long period of time,
 - if more than one person uses the device.
- Carefully disinfect, rinse with hot tap water and completely dry nebuliser kit and air tube after inhalation.
- Never leave disinfectant inside nebuliser kit or mouthpiece.
- Wet parts are to be completely dry. Store clean and dry parts in clean location.
- Do not store air tube if there is moisture or residues of medication inside it.

- Do not use and do not store device in an environment with noxious vapours, volatile substances or flammable gases.
- Do not block ventilation slots on device. During use do not cover device with a blanket or towel. The compressor could get hot and there is a possible risk of burn if touched.
- Before use, be sure nebuliser kit is clean.
- Always dispose remaining medication after inhalation. Always use a fresh dose of medication for each use.
- Do not use this device near anaesthetics or ventilator breathing circuits.
- Do not use this device in an oxygen rich environment.
- Do not make any unauthorised modification of this device

(Risk of electrical shock)

- Mains plug is considered as disconnecting device.
- Do not connect or disconnect power cord if your hands are wet.
- Compressor and power cord are not waterproof. Do not spill water or other liquids on these parts. In case of a liquid spilling, immediately disconnect power cord and wipe liquid with some absorbent material.
- Do not immerse device in water or other liquids.
- Do not use or store device in humid locations, such as a bathroom.
- Do not use device if power cord or plug is damaged.
- Keep power cord away from heated surfaces.
- Do not self-perform repairs of any kind. If fault occurs, contact an authorized PRIZMA service.

Read and follow instructions on “Important information regarding electromagnetic compatibility (EMC)”, section “Technical data” of this manual.

(Usage)

- Provide close supervision when this device is used by, on, or near children or persons with a disability.

- Do not use device while sleeping or if drowsy.
- Check that all parts are connected properly.
- Check that nebuliser kit is assembled and installed properly.
- Check that air filter is clean. If colour of the filter has changed or the filter has been used for more than 60 days, replace it with a new one.
- Check that the air filter is installed properly.
- Do not spill medication or water over compressor.
- During inhalation do not shake nebuliser kit.
- During inhalation do not tilt nebuliser kit more than 45°.
- Do not use or store device while air tube is creased.
- Use only original inhalation parts, air tube, air filter and filter cover.
- Do not add more than 6 ml of medication to the medication tank.
- Do not carry or leave nebuliser kit while the medication tank contains medication.
- Do not leave device unattended with infants or persons who cannot express their consent.
- Do not apply strong force to the device or parts of device. For example, dropping the device on the floor.
- Do not distort the vaporiser or jab the nozzle of the medication tank with a pin.
- Do not insert fingers or objects inside the compressor.
- Do not disassemble or attempt to repair compressor or power cord.
- Do not block the air filter cover.
- When sterilising parts by boiling, make sure that parts does not boil dry.
- Do not place or attempt to dry device or parts of device in a microwave oven.
- Do not attempt to dry device or parts of device by hair dryer.
- Approved for human use only.

(Risk of electrical shock)

- Plug the device into the appropriate voltage outlet. Do not overload power outlets or use extension cords.
- Always unplug the device from the power outlet after use and before cleaning.
- Do not bend power cord.
- Do not wrap power cord around compressor.

General safety precautions

- Each time before use, inspect the device and parts to check that there are no problems. In particular, check:
 - Vaporiser, nozzle and air tube are not damaged.
 - Nozzle is not blocked.
 - Compressor operates normally.
- During use of the device check that the compressor creates some noise and vibration. Also, compressed air leaving nebuliser kit produces some noise. This is normal and does not indicate a malfunction.
- Operate the device only as intended. Do not use the device for any other purpose.
- Do not use the device at temperatures greater than +40°C.
- Make sure that air tube is securely attached to the compressor (main unit) and nebuliser kit. Twist the air tube plug slightly when inserting it into connectors to avoid the air tube disconnecting during use.
- To completely isolate the device from the power source, unplug the plug from the power source.

Read and follow the “Correct disposal of this product”, section “Technical data” of this Instruction manual, when disposing of the device and any used accessories or optional parts.

Save this instructions for future reference!

1. Know your device

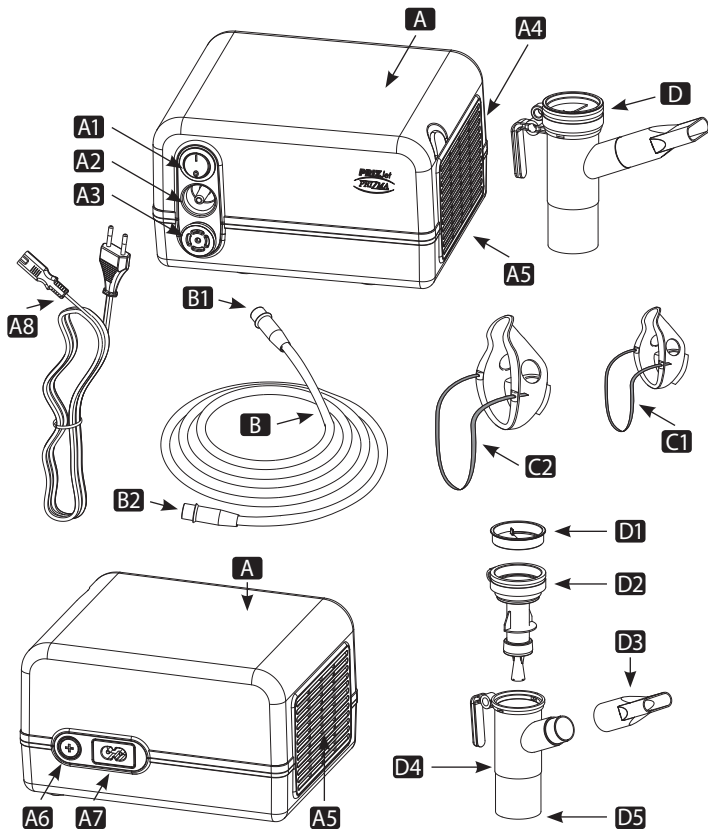

A. Compressor (main unit, PC)

- A1. Power switch
- A2. Air connector

A3. Filter cover (* Air filter inside)

- A4. Nebuliser kit holder
- A5. Ventilation slots

A6. Fuse holder

A7. Power jack

A8. Power cord

B. Air tube (PVC, 220 cm)

B1. Air plug

B2. Air plug

C. Inhalation attachments

C1. Adult mask (PVC)

C2. Child mask (PVC)

D. Nebuliser kit

D1. Top cover with air valve

D2. Vaporiser

D3. Mouthpiece

D4. Medication tank

D5. Air tube connector

Accessories

E. Spare air filters

F. Carrying bag

G. Instruction manual

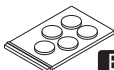

E



F



G

Material of attachment

Nebuliser kit	Polypropilene
Adult mask, Child mask	PVC phthalate free
Air tube	PVC phthalate free
Air filter	Polyester
Air filter cover	PC

Applied parts

According to standard IEC60601-1:2005 applied parts of this device are:

- Child mask
- Adult mask
- Nebuliser kit

2. Guide to using the PRIZJet

Preparing the nebuliser for use (Section 3)

Note: Clean and disinfect the nebuliser kit and applicable attachments before using the device for the first time, or if it has not been used for more than one week.



Taking medication (Section 4)

Note:

- Do not tilt nebuliser kit more than 45°.
- Do not crease or fold the air tube



Cleaning parts after use (Section 5)

Note:

Failure to clean the nebuliser parts after use may lead to infection.



How the nebuliser kit works

The compressed air from the compressor is forced through the nozzle. Inside the vaporiser head air is mixed with the medication. The mixture is directed to the baffle where it is broken down into small aerosol particles.

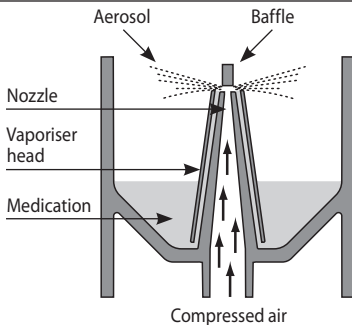

3. Preparing the nebuliser for use

Warning:

Clean and disinfect the nebuliser kit, mouthpiece or masks before using them for the first time or after purchase, if the device has not been used for a long period of time, or if more than one person uses the same device.

For directions on cleaning and disinfecting refer to Section 5 in this instruction manual.

Note: Regularly change the air filter (See Section 7 „Changing the air filter“).

1. Check that the power switch is into the (O) position.

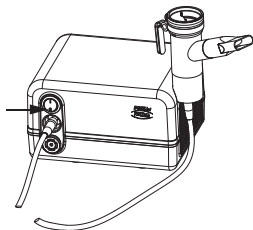

2. Plug the power cord into power jack at the rear side of compressor.

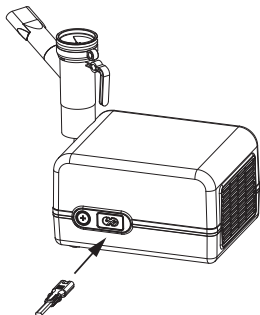

3. Plug the power plug into a power outlet.

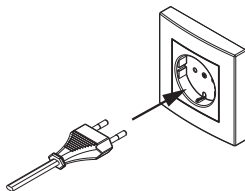

4. Remove the top cover from the medication tank.

- 1) Rotate top cover anti-clockwise.
- 2) Lift the top cover out of the medication tank.

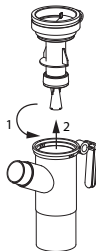

5. Add the correct amount of prescribed medication to the medication tank.

⚠ Caution: The capacity of the medication tank is 3 to 6 ml.

Note: Marks 3 ml and 6 ml on the medication tank are for reference only. Please use the scale on your syringe or vial for accurate measurement of medication.



6. Put the top cover back inside the medication tank.
- 1) Align the protrusions on the top cover with indent in the medication tank, as shown.
 - 2) Rotate the top cover clockwise and align with the medication tank until locking.

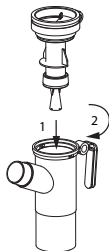

7. Attach the desired inhalation attachment, as described bellow

Attaching the mouthpiece

Attach the mouthpiece to the medication tank.

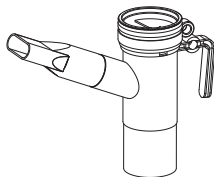
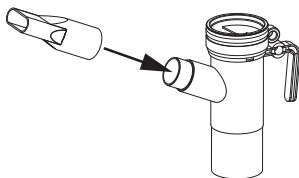

Attaching the adult mask

Attach the adult mask to the medication tank.

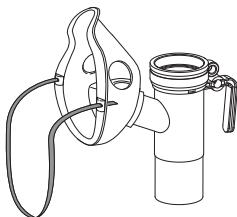
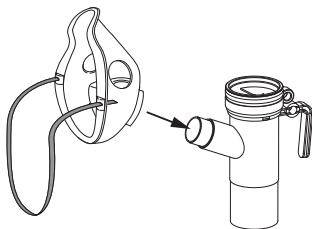

Attaching the child mask

Attach the child mask to the medication tank.

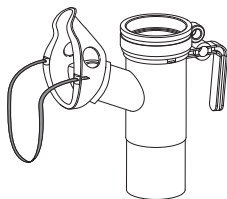
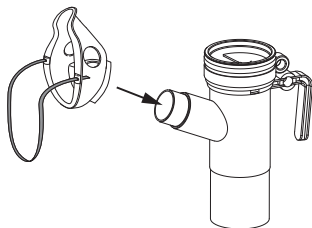

8. Attach the air tube.

- 1) Attach the air tube to the air connector on the compressor.

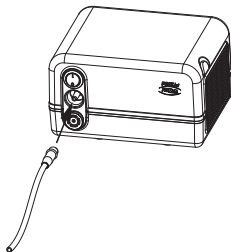

- 2) Attach the other end of the air tube to the air tube connector on the medication tank.

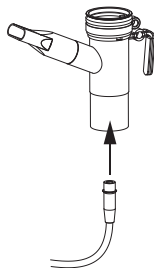

Notes:

- Make sure that air tube is securely attached to the compressor and nebuliser kit, and does not come loose. Twist the air tube plug slightly when inserting it into the connectors to avoid the tube disconnecting during use.
- Take care not to spill the medication when attaching the air tube. Keep the nebuliser kit upright.
- Use the nebuliser kit holder as a temporary holder for the nebuliser kit.

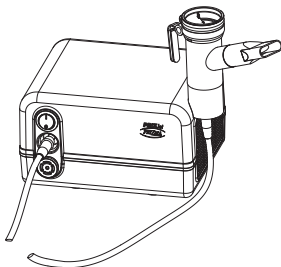

4. Taking medication

4.1 Inhalation

1. Hold the nebuliser kit as indicated in picture.

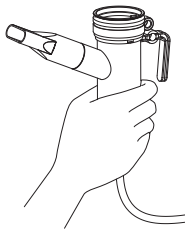

 **Caution:**

Do not tilt the nebuliser kit more than 45°, as medication may flow into the mouth.

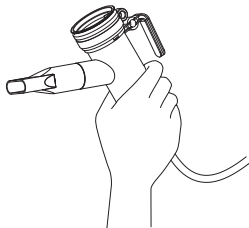

2. *To start the nebulisation*

Press the power switch to the on (I) position. The compressor starts.

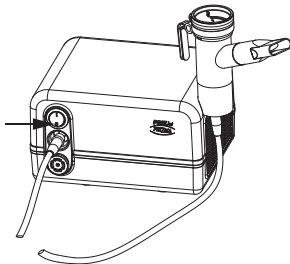

Note: Observe whether aerosol is generated.

To stop the nebulisation

Press the power switch to (O) position.

Warning:

Do not block the ventilation slots on the compressor. This could result in the compressor overheating or malfunctioning.

Caution:

Do not block the air filter cover.

Note: Do not leave the compressor on for a long period of time. This could result in the compressor overheating or malfunctioning.

3. Inhale medication according to your doctor's instructions.

Using the mouthpiece

Prepare your mouthpiece according to Section 3.7.

Insert the mouthpiece into your mouth and inhale the medication breathing normally. Exhale as normal through the mouthpiece.

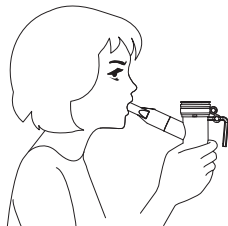
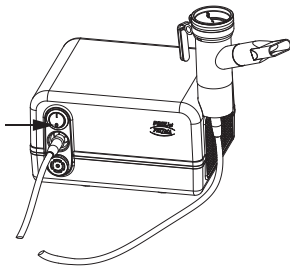

Using the adult or child mask

Prepare your adult or child mask according to Section 3.7.

Attach the mask so that it covers your nose and mouth and inhale the medication. Exhale through the mask.



4. When treatment is complete, turn the power off. Check that there is no condensation or moisture in the air tube.

Unplug the device from the power outlet.

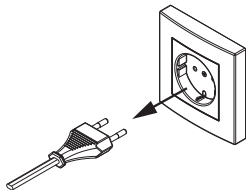

Warning:

Condensation may occur inside air tube. Do not store the air tube while it contains condensation or moisture. This could result in infection from bacteria.

Procedure for removal of moisture or liquid in the air tube is as follows:

- 1) Connect air tube to the air connector on the compressor.
- 2) Unplug nebuliser kit from air tube.
- 3) Turn on compressor and pump air through air tube until all liquid and moisture is purged from air tube.

Note:

- Tapping the side of the nebuliser occasionally helps the solution drop to where it can be converted to an aerosol.

Note:

- the rate of nebulisation can be adjusted by turning the air valve.

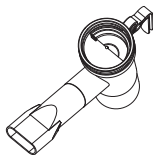

Opened air valve -
maximum flow

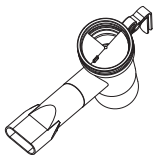

Closed air valve -
minimum flow

Top cover
with air valve



Vaporiser

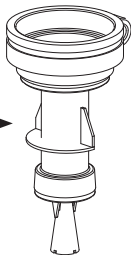

Mouthpiece

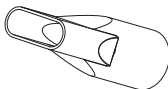

Medication tank

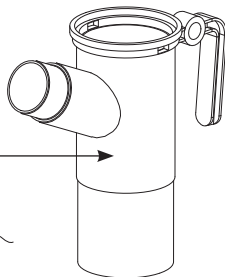

Air tube

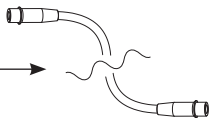

Air tube
connector

5. Cleaning and daily disinfecting

5.1 Cleaning

It is necessary to clean the device after each use. Cleaning will prevent drying of remaining medication inside the medication tank, remove moisture and condensation inside the air tube to prevent infections. Only a clean device will work effectively and safely.

⚠ Warning:

Thoroughly rinse the nebuliser and mask, nosepiece or mouthpiece with clean hot tap water after each use, and disinfect parts of the nebuliser kit and applicable inhalation attachments after the last treatment of the day.

Note: Do not start operation before the cleaned parts are completely dry.

1. Make sure that the power switch is in **O** (off) position
2. Unplug the power cord from the electrical outlet.
3. Disconnect the nebuliser kit from the air tube and disassemble it (see Section 3).
4. Discard any remaining medication in the medication tank.
5. Wash all the nebulising parts in warm water and mild detergent and rinse in clean hot tap water, or wash in dishwasher.

For instructions on how to disinfect the parts, see Section 5.2.



6. After cleaning and disinfecting the parts, rinse them thoroughly with clean water and allow the parts to air dry in a clean environment.

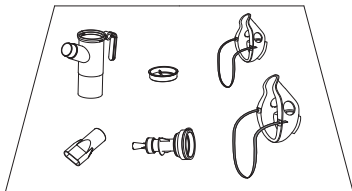

7. If the compressor is dirty, wipe it clean with a soft cloth slightly moistened with water or mild detergent.

Caution:

⚠ The compressor is not waterproof.

8. If the outside of the air tube is dirty, wipe it clean with a soft cloth moistened with water or mild detergent.
9. If there is condensation or moisture inside air tube, connect air tube to the air connector on the compressor (opposite air tube end must be disconnected from nebuliser kit), turn on the compressor and pump air through air tube until all liquid and moisture is purged from air tube.
10. Reassemble the nebuliser kit. Put the parts in a dry, sealed bag and place in the storage pocket of carrying bag.

Note: Nebuliser kit should be replaced after 12 months of use.

5.2 Disinfecting the nebulising parts

Always clean parts before disinfection (See Section 5.1).

Always disinfect parts of nebuliser kit, used mouthpiece and masks after the last treatment of the day. All mentioned parts can be disinfected by alcohol.

Put parts needed sterilisation (**NOT** compressor) into 70% ethyl-alcohol (medical grade alcohol) about 1 minute. Shake excess of alcohol from parts and allow them to dry in a clean environment.

Note: DO NOT put compressor in disinfecting solution.

6. Maintenance and storage

To keep your device in the best condition and protect it from damage follow these directions:

⚠ Caution:

- Do not leave the device unattended with infants or persons who cannot express their consent.
- Do not subject the device or parts to any strong shocks such as dropping the device on the floor.

Notes:

- Do not store the device in extreme hot or cold temperatures, high humidity or under direct sunlight.
- Do not crease or fold the air tube.
- Dispose the device and any used accessories or optional parts according to applicable local regulations.
- Never clean with benzene, thinners or a flammable chemicals.

Always transport the device in its carrying bag, and store the device in the bag if it will not be used for a long period of time.

⚠ Caution:

Do not carry or leave the nebuliser while the medication tank contains medication.



7. Changing the air filter

The air filter should be replaced after 60 days of use or when the filter has changed colour.

1. Pull the air filter cover off the compressor.

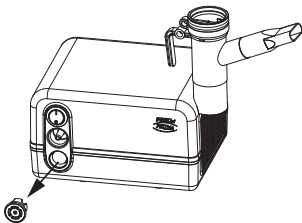

2. Remove the old air filter with a sharp object, such as toothpick, and insert the new air filter.

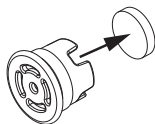

3. Insert the new filter in the air filter cover.

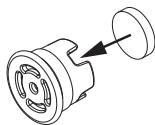

4. Put the air filter cover back in place.

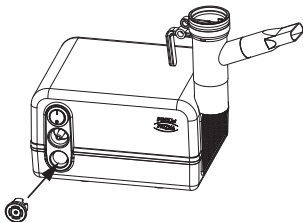
**Notes:**

- Use only original air filters designed for this device. Do not operate without a filter.
- There is no front or back orientation for the air filter.
- Check that air filters are clean and free of dust before inserting them.
- Do not attempt to wash or clean the air filter. If the filter becomes wet, replace it. A damp air filter can cause blockages.
- To prevent the air filter cover from becoming blocked, wash the air filter cover regularly. Do not boil the air filter cover. Remove the air filter cover, wash it, and make sure it is dry and reattached correctly.
- Please contact your PRIZMA dealer for additional filters, or if the parts supplied with the device are damaged or missing.

8. Troubleshooting

Check the following if your device should fail during operation. You can also refer to the pages of this Instruction manual for complete instructions.

<i>Symptom</i>	<i>Cause</i>	<i>Remedy</i>
Nothing happens when the power switch is pressed.	Is the power cord plugged into the compressor and an electrical outlet?	Check that plug is inserted into the jack on rear side of compressor and in an electrical outlet. Unplug, then reinsert the plugs if necessary.
	Is fuse on rear side of the compressor ok?	Remove fuse cap on the rear side of the compressor. Remove blown fuse. Insert a new fuse in fuse holder. Insert and lock fuse cap.
No nebulisation or low nebulisation rate, when the power is on.	Is there medication in the medication tank?	Fill the medication tank.
	Is there too much/little medication in the medication tank?	Add the correct amount of medication to the medication tank.
	Is there vaporiser missing and not assembled correctly?	Attach the vaporiser correctly.
	Is the nebuliser kit assembled correctly?	Attach the nebuliser kit correctly.
	Is the nozzle blocked?	Make sure that nozzle is free of blockages.
	Is the nebuliser kit tilted at a sharp angle?	Make sure that the nebuliser kit is not tilted at an angle more than 45 degrees.
	Is the air tube connected correctly?	Make sure that the air tube is correctly connected to the compressor and nebuliser.
	Is the air tube folded or damaged?	Make sure that the air tube does not contain kinks.
	Is the air tube blocked?	Make sure that the air tube is free of blockages?
	Is the air filter dirty?	Replace the air filter with a new one.

<i>Symptom</i>	<i>Cause</i>	<i>Remedy</i>
The device is abnormally loud.	Is the air filter cover attached correctly?	Attach the air filter cover correctly.
The device is very hot.	Are the ventilation slots blocked?	Do not block the ventilation slots.

Notes:

- If the suggested remedy does not solve the problem, do not try to repair the device - no parts of the device are user serviceable. Return the device to an authorized PRIZMA retail outlet or distributor.
- The device should be serviced once a year by an approved PRIZMA service centre.

9. Technical data

Model	Compressor nebuliser PRIZJet
Type	Non-heating compressor nebuliser
Electrical	230V, 50Hz
Power consumption	50W
IP classification*	IP21
Operating temperature/ humidity/air pressure	+5°C to +40°C / 15% to 93% RH / 700 hPa to 1060 hPa
Storage temperature/ humidity/air pressure	-25°C to +70°C / up to 93% RH / 700 hPa to 1060 hPa
Weight	1.3 kg (compressor only)
Dimensions	180 (W) x 110 (H) x 140 (D) mm
Contents	Compressor (PC), Nebuliser kit (Polypropilene), Air tube (PVC phthalate free), 5 pcs Replacement filters (Polyester), Adult mask (PVC phthalate free), Child mask (PVC phthalate free), Carrying bag, Instruction manual.

*IP classification is degree of protection provided by IEC 60529. This unit is protected against solid foreign objects of diameter 12.5 mm such as a finger and greater. This unit is protected against the ingress of vertically falling water drips.

Notes:

- Subject to technical modification without prior notice.
- This PRIZMA product is produced under the strict quality system of PRIZMA d.o.o, Serbia.
- The device may not work if the temperature or voltage conditions are different to those defined in the specifications.

Technical data for the PRIZMA PRIZJet compressor with the Atlantean AT-Neb Nebuliser kit

Particle size:	*MMAD 3µm
Medication tank capacity:	6 ml maximum
Appropriate medication quantities:	3 ml minimum - 6 ml maximum
Sound:	Noise level (at 1 m distance) < 60 dB (A)
Nebulisation rate:	>0.3 ml/min (by weight loss)
<i>*MMAD = Mass Median Aerodynamic Diameter</i>	

Notes:

- Performance may vary with drugs such as suspensions or high viscosity. See drug supplier's data sheet for further details.
- See web of PRIZMA to update technical informations.

Notes:



= Tip BF

CE 1304

Do not use the device where it may be exposed to flammable gas. This device fulfils the provisions of the EC directive 93/42/EEC (Medical Device Directive) and European standard EN13544-1:2007+A1:2009, Respiratory therapy equipment - Part 1: Nebulising systems and their components.



= Class II



= Read the instructions manual carefully

Important information regarding Electro Magnetic Compatibility (EMC)

With the increased number of electronic devices such as PC's and mobile (cellular) telephones, medical devices in use may be susceptible to electromagnetic interference from other devices. Electromagnetic interference may result in incorrect operation of the medical device and create a potentially unsafe situation. Medical device should also not interfere with other devices.

In order to regulate the requirements for EMC (Electro Magnetic Compatibility) with the aim to prevent unsafe product situations, the EN60601-1-2 standard has been implemented. This standard defines the levels of immunity to electromagnetic interferences as well as maximum levels of electromagnetic emissions for medical devices.

This medical device manufactured by PRIZMA conforms to this EN60601-1-2:2007 standard for both immunity and emissions.

Nevertheless, special precautions need to be observed:

- Do not use mobile (cellular) telephones and other devices which generate strong electrical or electromagnetic fields near medical device. This may result in incorrect operation of the unit and create potentially unsafe situation. Recommendation is to keep a minimum distance of 7 m. Verify correct operation of device in case the distance is shorter.

Further documentation in accordance with EN60601-1-2:2007 is available at PRIZMA at address mentioned in this instruction manual.

Documentation is also available at www.prizma.rs.

**Correct disposal of this product
(Waste electrical & electronic equipment)**

This marking shown on the product or its literature indicates that it should not be disposed of with other household wastes at the end of its working life. To prevent possible harm to environment or human health from uncontrolled waste disposal, please separate this from other types of wastes and recycle it responsibly, to promote sustainable reuse of material resources.

Household users should contact either the retailer where they purchased this product or their local government office for details of where and how they can take this item for environmentally safe recycling.

Business user should contact their supplier and check the terms and conditions of purchase contract. This product should not be mixed with other commercial wastes for disposal.

This product does not contain any hazardous substances.

10. Optional parts and accessories



Nebuliser kit SET
(Catalogue Code: PJNKS)

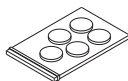

Air filters (x 5)
(Catalogue Code: PJAF)



Carrying bag
(Catalogue Code: PJCB)



Filter cover
(Catalogue Code: PJCF)



Instruction manual

<p>Manufacturer</p> 	<p>PRIZMA d.o.o. Kumanovska 8, 34000 Kragujevac, Serbia www.prizma.rs</p>		
<p>EU-representative</p> <table border="1" data-bbox="74 1209 236 1275"> <tr> <td>EC</td> <td>REP</td> </tr> </table>	EC	REP	<p>GRAJSKA VRATA d.o.o Šmiklavž 3a, 3324 Gornji Grad, Slovenia</p>
EC	REP		
<p>Production facility</p>	<p>PRIZMA d.o.o. Zorana Đinđića 13, 34000 Kragujevac, Serbia</p>		

